

MIFARE & ISO14443A & ISO14443B & ISO15693 & ISO18000 & ISO18092 IC CARD MODULE

JMY6223 IC Card Reader

User's manual

(Revision V1.02)

Beijing Jinmuyu Electronics Co. LTD

2025/11/26



Please read this manual carefully before using. If any problem, please mail to: Jinmuyu@vip.sina.com



Contents

1	Product Introduction.....	2
2	Key Characteristics	2
3	Characteristics	2
4	Physical Parameter and Pin Outs.....	3
4.1	Photo (Front and Back of JMY6223)	3
4.2	Dimension.....	4
4.3	Pin configurations and Pin out.....	5
4.4	Method of attachment.....	6
4.5	MT-500 Test Board.....	6
4.6	Antennas	7
4.7	Module Function Configuration Table	8
5	Communication Protocols	8
6	Document update history	9



1 Product Introduction

JMY6223 is a modular circuit. User need send the reading or writing commands to the Contactless IC Card via it. This module complies with LEVEL 1 standard of EMV2000, EMV2010 and PBOC 2.0.

JMY6223 adopts a split design, uses a 50ohm coaxial cable to connect the outside antenna, and is used an impedance analyzer to adjust the RF circuit and the antenna to match the impedance, which can achieve very good read and write performance and very good stability.

JMY6223 adopts a surface mount installation form, and its ultra-small size is a major feature.

JMY6223 has many functions, supports a variety of international standards contactless IC cards, and supports cards from many different suppliers. The designer has classified and integrated the commands of the contactless IC card, so the commands issued by the user to the module are relatively simple, but they can complete the overall operation of various contactless IC cards.

2 Key Characteristics

- Using 50ohm coaxial cable to connect the outside antenna, the antenna can be customized and flexible antenna size and layout.
- Low power consumption, ultra-small size surface mount and other characteristics make it very suitable for battery-powered equipment such as handhelds.
- Complete support for T=CL cards, support FSDI=8, and can send and receive APDUs of more than 256 bytes.
- The RF circuit performance and communication protocol of the module can be certified by EMV or PBOC.

3 Characteristics

- PCD model: NXP CL RC663
- Working frequency: 13.56MHz
- Supported standard: ISO14443A,ISO14443B,ISO15693, Felica, ISO18092
- 50ohm coaxial cable: 30cm, 60cm or 150cm;can be customized
- Card supported: Reference: [module function configuration table](#)
- Anti collision ability: Full function anti collision; be able to process multi-cards; be able to set operate single card only.
- Auto detecting card: Supported, default OFF. The default state can be set
- Power supply: DC 3.3V & 5V
- Interface: IIC and UART (selected by SPS pin, IIC is recommended)
- Communication rate: IIC 400Kbps
UART 19200bps / 9600bps / 38400bps / 57600bps / 115200bps
- Max. command length: JCP04 253bytes



- Interface level: JCP05 510bytes
- Power consumption: UART/IIC: 3.3V(TTL level)
- Power consumption: Max. 150mA
- Operating distance: 100mm (related to card and antenna design)
- Dimension: 22mm*35mm*4.1mm
- Package form: Surface mount
- Weight: About 10g (without Antenna)
- ISP: Supported
- Operating temperature: -25 ~ +85 °C
- Storage temperature: -40 ~ +125 °C
- RoHS: Supported

4 Physical Parameter and Pin Outs

4.1 Photo (Front and Back of JMY6223)

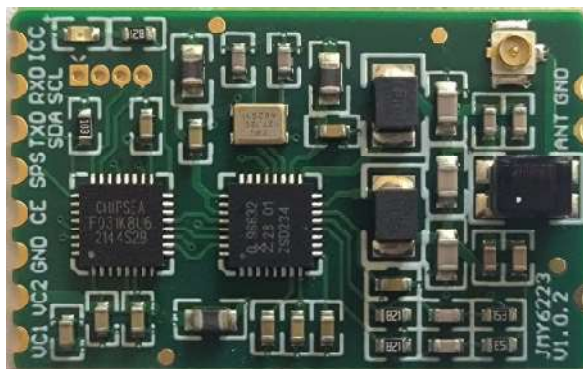



4.2 Dimension

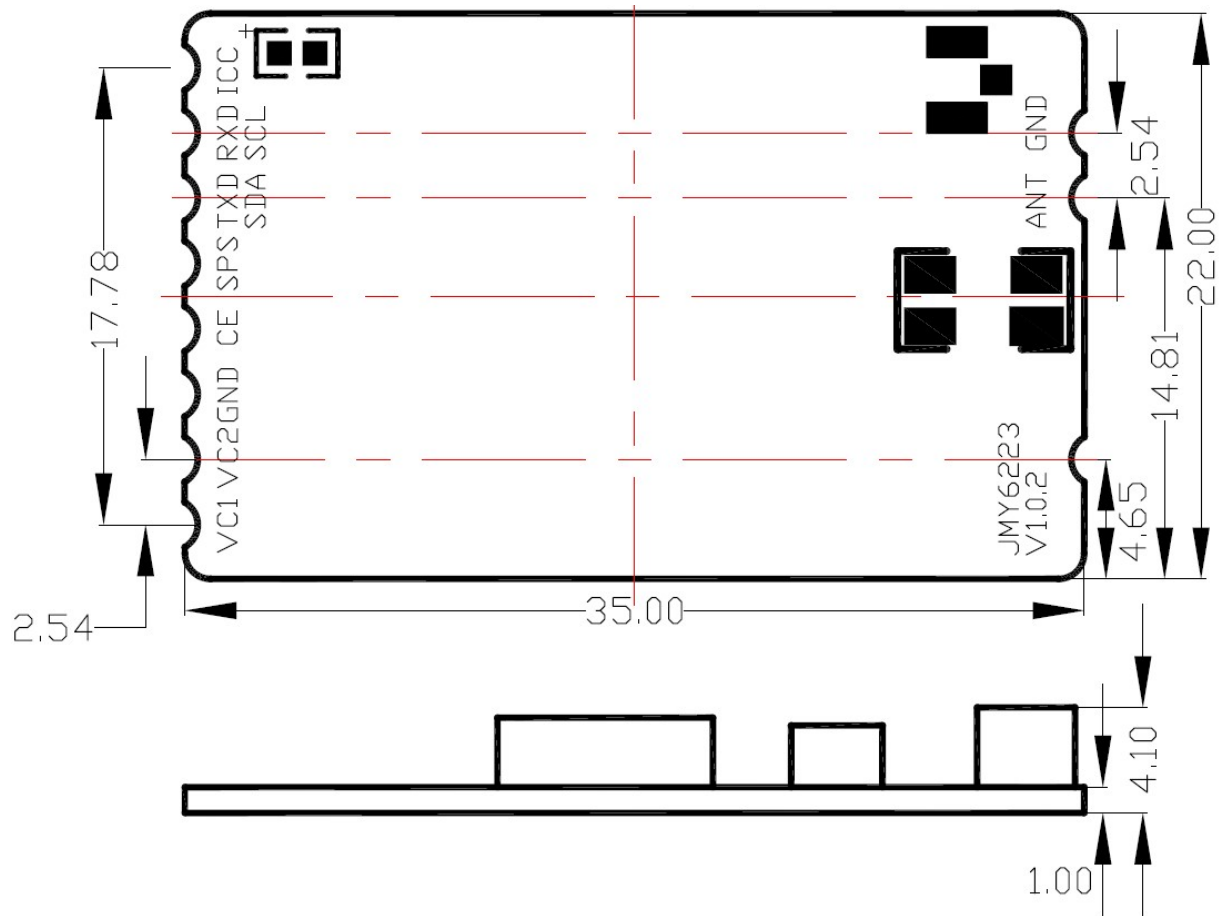



4.3 Pin configurations and Pin out

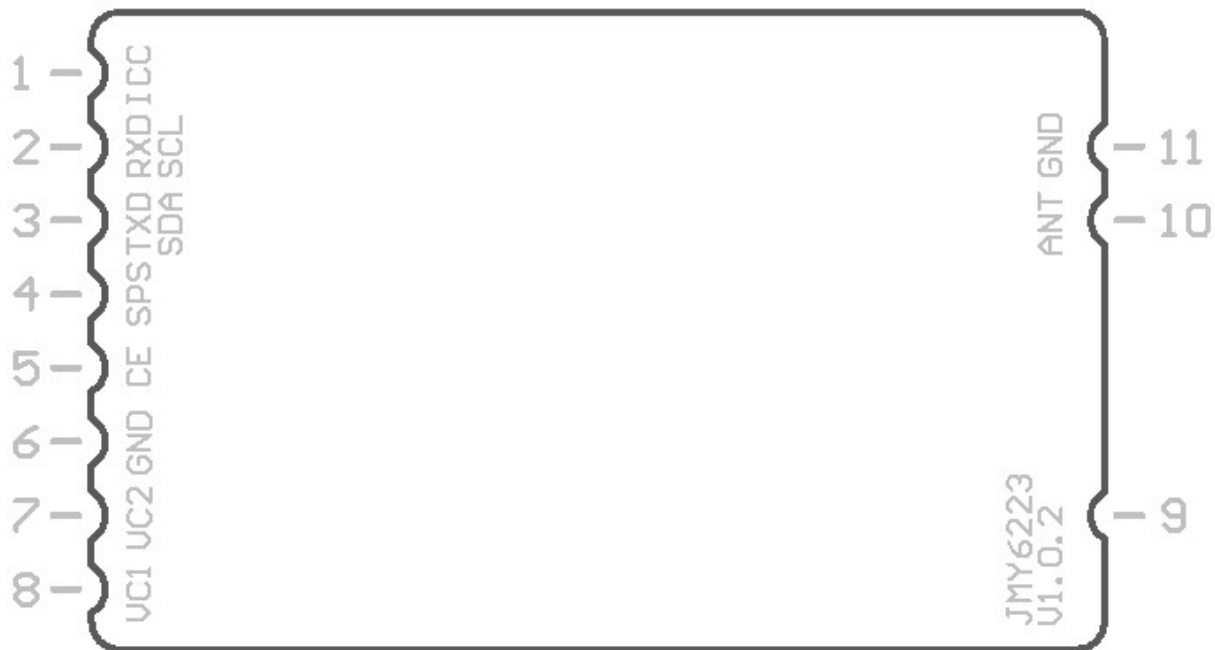

Pin number	Function	Type	LOW	HIGH	Description
1	ICC	Output	0V	3.3V	Card in/out indicator, 0: Card IN; 1: Card OUT
2	RXD/SCL	Input	0V	3.3V	UART RXD / IIC SCL
3	TXD/SDA	Input / Output	0V	3.3V	UART TXD / IIC SDA
4	SPS	Input	0V	3.3V	Serial port select, 1: UART; 0: IIC
5	CE	Input / Output	0V	3.3V	Module enable, 1: disable; 0: enable
6	GND	GND	0V	/	GND
7	VCC2	Power	/	3.3V	MCU Power
8	VCC1	Power	/	5V	RF Power
9	GND	GND	0V	/	For fixing use, connect to GND
10	ANT	RF Output	/	/	50-ohm antenna connection point (leave unused)
11	GND	GND	0V	/	50ohm antenna connection point



4.4 Method of attachment

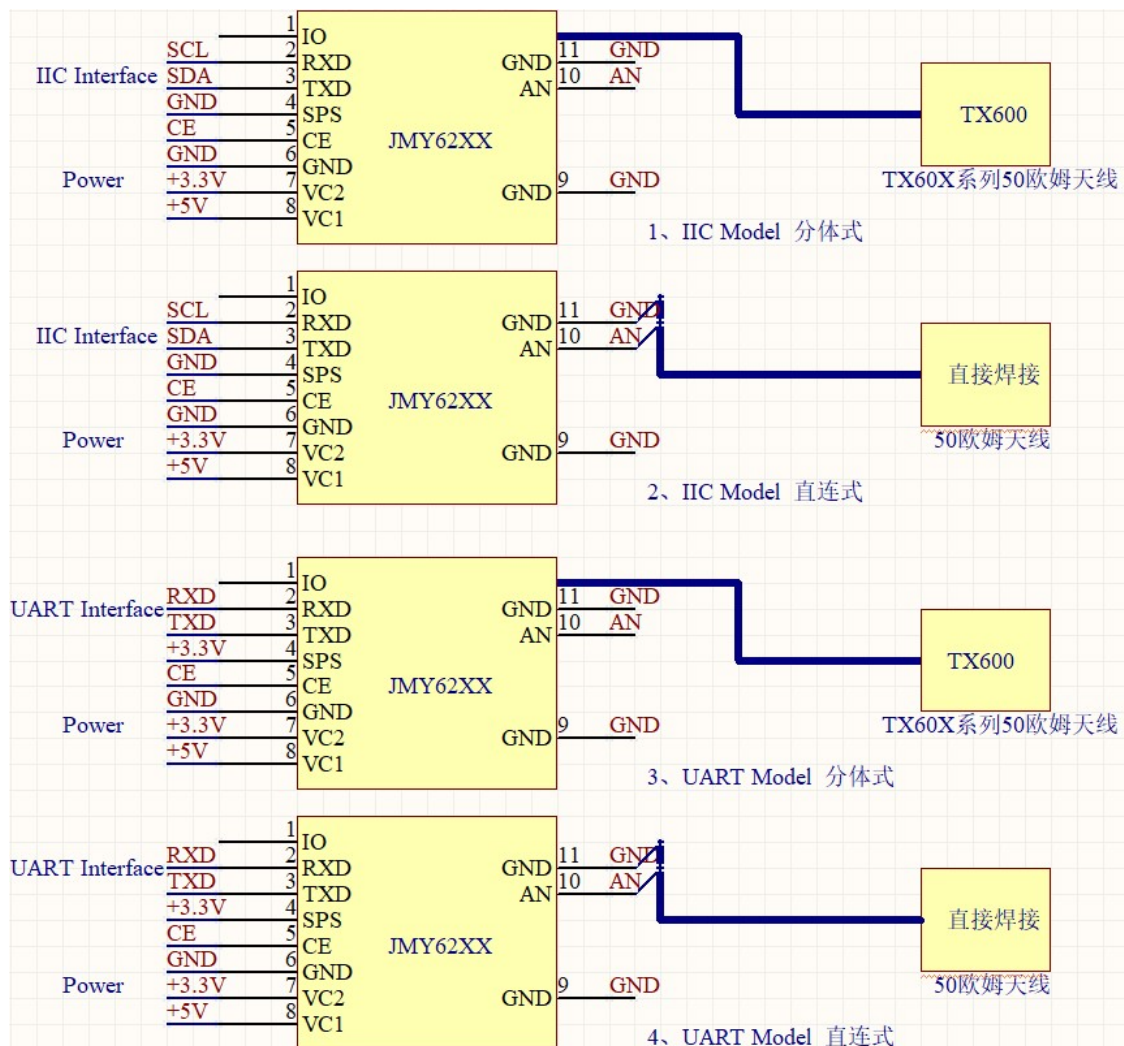

4.5 MT-500 Test Board

The MT-500 test board is a specialized experimental tool designed for developing JMY62XX series modules. Users can use the MT-500 to perform rapid quality testing and development experiments on the modules.

The MT-500 uses a 51 microcontroller to operate the modules and can switch communication ports (IIC or UART). Based on the provided source code (including IIC and UART), users can quickly program the application system.

The MT-500 can also communicate with a PC via an RS232 port. PC users can then develop test software on their PCs to test the modules.

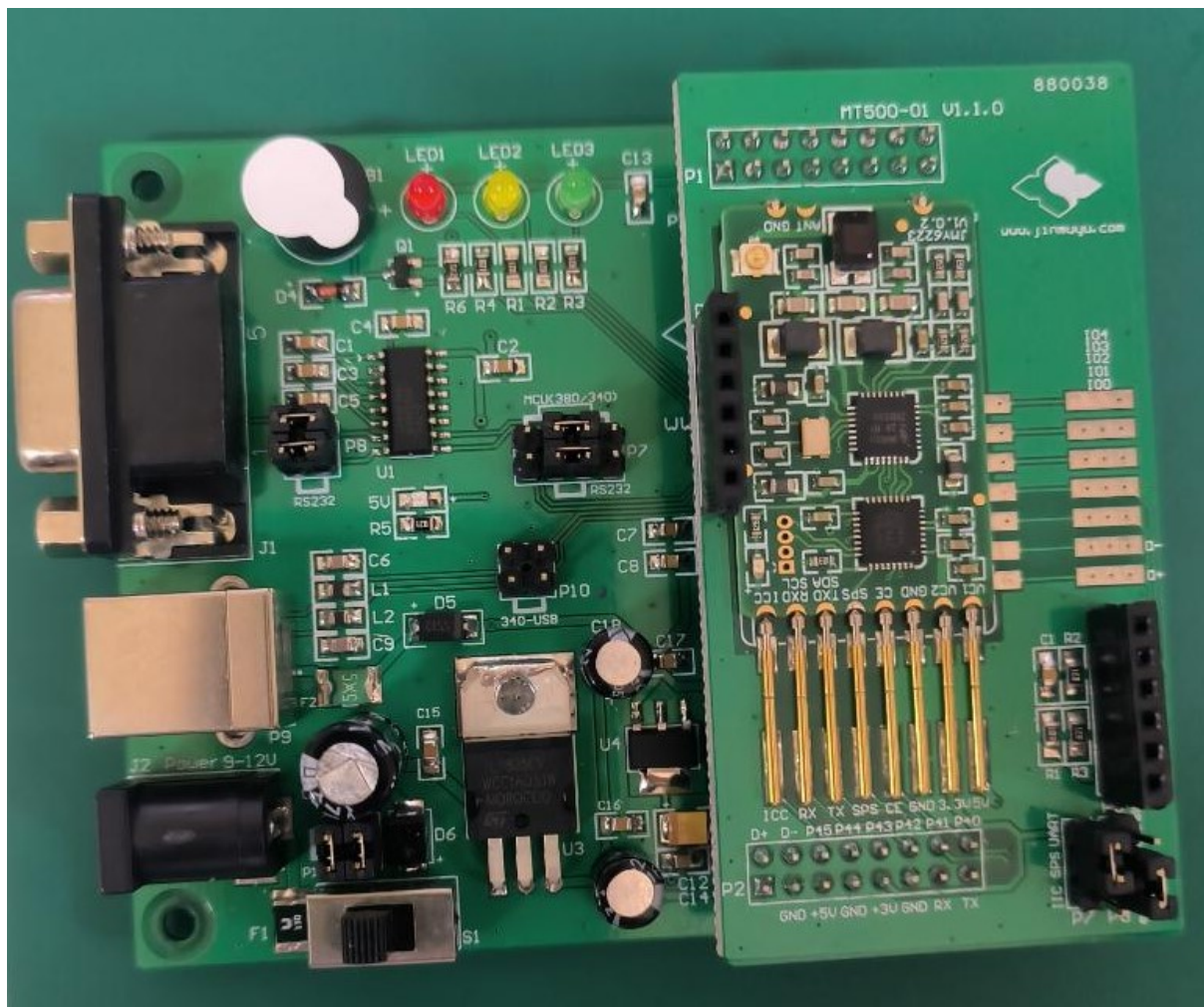

4.6 Antennas

Normally, as the size of TX600 series antenna may not meet the actual demands, the antenna needs to be customized, especially in some compact systems. The following information for customization is needed:

1. Dimension of the antenna PCB;
2. The position and direction of the antenna outlet and the connector;
3. The description of the antenna periphery. JINMUYU will design the most proper antenna according to the user's exact requirements.

We provide many models of antennas. There are some standard recommended models in the table:

Antenna model	Dimension	Reading distance
TX600	70mm * 70mm	100mm
TX601	50mm * 50mm	70mm
TX602	30mm * 30mm	50mm
TX604	50mm * 70mm	80mm
TX605	100mm*150mm	100mm



4.7 Module Function Configuration Table

	JMY6223
PCD	NXP CL RC663
JCP04 Communication Protocol	●
JCP05 Communication Protocol	●
MIFARE 1K	●
MIFARE 4K	●
MIFARE Ultra Light	●
MIFARE Ultra Light C	●
MIFARE Mini	●
MIFARE DES fire	●
MIFARE Plus	●
T=CL TYPE A	●
SR176	●
SRI512	●
SRI1K	●
SRI2K	●
SRI4K	●
SRIX4K	●
T=CL TYPE B	●
I.CODE SLI	●
I.CODE SLI-S	●
TI Tag-it Series	●
ST LRI Series	●
NFC Reader	●
FELICA	●
FLASH in MCU	1Kbytes
IIC Interface	●
UART Interface	●

5 Communication Protocols

The physical interfaces of module are various. But the data link layer protocols are in accordance with JCP04 and JCP05. Please reference "JMY600 Series IC Card Module General Technical Manual".

For convenience to test the Module, we supply PC software: TransPort to users.

We have interface program source code to help users also. They are KELL projects in C51 or ASM51 format.

Please log in our website: www.jinmuyu.com to download or mail to jinmuyu@vip.sina.com to obtain



the resources.

6 Document update history

Version	Date	Details
V1.00	October 16, 2024	Create a new file
V1.01	February 18, 2025	Modify the interface level description
V1.02	November 26, 2025	Modify level description and resolve errors